

PRACTICAL MANUAL

Course Title	: Farm Machinery and Power
Credits	: 2 (1+1)
Course No.	: ENGG - 232
Course	: B.Sc. (Hons.) Agriculture
Semester	: III Semester (New)



Compiled by

Prof. B.P. Sawant
Prof. A.R. Mantri

Under the Guidance of Dr. U.M. Khodke, Head

Department of Agril. Engineering,
College of Agriculture, Parbhani

**Vasant Rao Naik
Marathwada Krishi Vidyapeeth,
Parbhani : 431 402**

(2018)

Exercise No. 1: Study of components of Internal Combustion (I. C.) Engine

Engine Components

Internal combustion engine consists of a number of parts, which are given below:

1. Cylinder:

It is a part of the engine, which confines the expanding, gases and forms the combustion space. It is the basic part of the engine. It provides space in which piston operates to such the air or air-fuel mixture. The piston compresses the charge and the gas is allowed to expand in the cylinder, transmitting power for useful work. Cylinders are usually made of high-grade cast iron.

i. Cylinder Block:

It is the solid casting, which includes the cylinder and water jackets (cooling fins in the air-cooled engines).

ii. Cylinder Head:

It is a detachable portion of an engine, which covers the cylinder and includes the combustion chamber, spark plugs and valves.

iii. Cylinder Liner or Sleeve:

It is a cylindrical lining either wet or dry, which is inserted in the cylinder block in which the piston slides. Cylinder liners are fitted in the cylinder bore and they are easily replaceable. The overhauling and repairing of the engines, fitted with liners is easy and economical. Liners are classified as:

Dry liner and (2) Wet Liner.

Dry liner makes metal to metal contact with the cylinder block casing. Wet liners come in contact with the cooling water, whereas dry liners do not come in contact with cooling water.

2. Piston:

It is a cylindrical part closed at one end and which maintains a close sliding fit in the engine cylinder. It is connected to the connecting rod by a piston pin. The force of the expanding gases against the closed end of the piston forces the piston down in the cylinder. This causes the connecting rod to rotate the crankshaft. Cast iron is chosen due to its high compressive strength, low coefficient of expansion, resistance to high temperature ease of casting and low cost. Aluminum and its alloys are preferred mainly due to its lightness.

i. **Head (Crown) of Piston:** It is the top of the piston.

ii. **Skirt:** It is that portion of the piston below the piston pin, which is designed to absorb the side movements of the piston.

iii. **Piston Ring:** It is a split expansion ring, placed in the groove of the piston, piston rings are fitted in the grooves, made in the piston. They are usually made of cast iron or pressed steel alloy. The functions of the ring are as follows:

- (a) It forms a gas tight combustion chamber for all positions of piston.
- (b) It reduces contact area between cylinder wall and piston wall for preventing friction losses and excessive wear.

- (c) It controls the cylinder lubrication
- (d) It transmits the heat away from the piston to the cylinder walls. Piston rings are of two types:
 - (1) Compression ring and (2) oil ring.

a. Compression Ring: Compression rings are usually plain, single piece and are always placed in the grooves, nearest to the piston head.

b. Oil Ring:

Oil rings are grooved or slotted and are located either in lowest groove above the piston pin or in a groove above the piston skirt. They control the distribution of lubrication oil in the cylinder and the piston. They prevent excessive oil consumption also. Oil ring is provided with small holes through which excess oil returns back to the crankcase chamber. Ring clearance is the gap at the joint of the ring, measured when the ring is inside the cylinder. The gap is usually 1 mm per 200 mm diameter of the piston. This clearance is necessary for expansion of the ring in heated condition, without which the ring can break or buckle.

iv. Piston Pin:

It is also called wrist pin or gudgeon pin. Piston pin is used to join the connecting rod to the piston. It provided a flexible or hinge like connection between the piston and the connecting rod. It is usually made of case hardened alloy steel.

3. Connecting Rod:

It is special type of rod, one end of which is attached to the piston and the other end to the crankshaft. It transmits the power of combustion to the crankshaft and makes it rotate continuously. It is usually made of drop forged steel. Its small end is fitted with bronze bushing and big end is provided with bearings split into two shells.

4. Crankshaft:

It is the main shaft of an engine, which converts the reciprocating motion of the piston into rotary motion of the flywheel. Usually the crankshaft is made of drop forged steel or cast steel. The space that supports the crankshaft in the cylinder block is called main journal, whereas the part to which connecting rod is attached is known as crank journal. Crankshaft is provided with counter weights throughout its length to have counter balance of the unit. Split shell bearings are mostly used as main bearings as well as twisting from the connecting rod end.

5. Flywheel:

Flywheel is made of cast iron. Its main functions are as follows:

- (a) It stores energy during power stroke and returns back the same energy during the idle strokes, providing a uniform rotary motion by virtue of its inertia.
- (b) It also carries ring gear that meshes with the pinion of starting motor.
- (c) The rear surface of the flywheel serves as one of the pressure surface for the clutch plate.
- (d) Engine timing marks are usually stamped on the flywheel, which helps in adjusting the timing of the engine.
- (e) Sometime the flywheel serves the purpose of a pulley for transmitting power.

6. Crankcase:

The crankcase is that part of the engine, which supports and encloses the crankshaft and camshaft. It provides a reservoir for the lubricating oil of the engine. It also serves as a mounting unit for such accessories as the oil pump, oil filter, generator, starting motor and ignition components. The upper portion of the crankcase is usually integral with cylinder block. The lower part of the crankcase is commonly called oil pan and is usually made of cast iron or cast aluminium.

7. Camshaft:

It is a shaft which raise and lowers the inlet and exhaust valves at proper time. Camshaft is driven by crankshaft by means of gears, chains or sprockets. The speed of the camshaft is exactly half the speed of the crankshaft in four-stroke engine. Camshaft operates the ignition timing mechanism. Lubricating oil pump and fuel pump. It is mounted in the crankcase, parallel to the crankshaft.

8. Timing Gear:

Timing gear is a combination of gears, one gear of which is mounted at one end of the camshaft and the other gear on the end of the crankshaft. Camshaft gear is bigger in size than that of the crankshaft gear. For this reason, this gear is commonly called half time gear. Timing gear controls the timing of ignition, timing of opening and closing of valves as well as fuel injection timing.

9. Inlet Manifold:

It is that part of the engine through which air or air-fuel mixture enters into the engine cylinder. It is fitted by side of the cylinder head.

10. Exhaust Manifold:

It is that part of the engines through which exhaust gases go out of the engine cylinder. It is capable of withstanding high temperature of burn gases. It is fitted by the side of the cylinder head.

Materials of construction of engine parts

Engine parts	Materials used
1. Cylinder head	Cast iron, Cast Aluminum
2. Cylinder liner	Cast iron, Cast steel
3. Engine block	Cast iron, Cast Aluminum
4. Piston	Cast iron, Aluminum alloy
5. Piston pin	Forged steel, Aluminum alloy
6. Piston ring	Forged steel alloy, Cast Aluminum
7. Connecting rod	Forged steel, Aluminum alloy
8. Main bearing	White metal
9. Connecting rod bearing	Bronze
10. Crank shaft	Cast steel, forged steel
11. Cam shaft	Forged steel, cast iron
12. Timing gear	Cast iron
13. Manifolds	Cast iron
14. Fly wheel	Cast iron
15. Gasket	Cork, copper, asbestos
16. Crankcase	Cast iron, Cast Aluminum

Exercise No. 2:**Study of Two Stroke Cycle Engine****Two Stroke Cycle Engine:**

In such engines, the whole sequence of events i.e. suction, compression, power and exhaust are completed in two strokes of the piston and one complete revolution of the crankshaft. There is no valve in this type of engine. Gas movement takes place through holes called ports in the cylinder. The crankcase of the engine is gas tight in which the crankshaft rotate-s.

First Stroke (Suction + Compression):

When the piston moves up the cylinder it covers two of the ports, the exhaust port and the transfer port, which are normally almost opposite to each other. This traps a charge of fresh mixture in the cylinder and further upward movement of the piston compresses this charge. Further upward movement of the piston also uncovers a third port in the cylinder called suction port. More fresh mixture is drawn through this port into the crankcase. Just before the end of this stroke, the mixture in the cylinder is ignited as in the four-stroke cycle.

Second Stroke (Power + Exhaust):

The rise in pressure in the cylinder caused by the burning gas forces the piston to move down the cylinder. When the piston goes down, it covers and closes the suction port, trapping the mixture drawn into the crankcase during the previous stroke then a compressing it. Further downward movement of the piston uncovers first the exhaust port and then transfers port. This allows the burnt gases to flow out through exhaust port. Also the fresh mixture under pressure in the crankcase is transferred into the cylinder through transfer port during this stroke. Special shaped piston crown deflects the incoming mixture up around the cylinder so that it can help in driving out the exhaust gases.

When the piston is at the top of its stroke, it is said to be at the top dead centre (TDC). When the piston is at the bottom of its stroke, it is said to be at its bottom dead centre (BDC). In two-stroke cycle engine, both the sides of the piston are effective which is not the case in four stroke cycle engine.

Scavenging:

The process of removal of burnt or exhaust gases from the engine cylinder is known as scavenging. Entire burnt gases do not go out in normal stroke, hence some type of blower or compressor is used to remove the exhaust gases in two-stroke cycle engine.

Comparison between two stroke and four stroke engine

Four Stroke Engine	Two Stroke Engine
1. One power stroke for every two revolution of the crankshaft	: One power stroke for each revolution of the crankshaft
2. There are inlet and exhaust valves in the engine	: There are inlet and exhaust ports instead of valves
3. Crankcase is not fully closed and air tight	: Crankcase is fully closed and air tight.
4. Top of the piston compresses the charge	: Both sides of piston compresses the charge
5. Size of the flywheel is comparatively larger	: Size of the flywheel is comparatively smaller

6

6. Fuel is fully consumed	:	Fuel is not fully consumed
7. Weight of engine per hp is high	:	Weight of engine per hp is comparatively low
8. Thermal efficiency is high	:	Comparatively low
9. Removal of exhaust gases easy	:	Removal of exhaust gases comparatively difficult
10. Torque produced is even	:	Torque produced is less even
11. All types of speed are possible	:	Mostly high speed engines are there
12. It can be operated in one direction only	:	It can be operated in both direction

Comparison of Diesel Engine and Petrol Engine

Diesel Engine		Spark Ignition (Petrol) Engine
1. It has got no carburetor, ignition coil and spark plug	:	It has got carburetor, ignition coil and spark plug.
2. It's compression ratio varies from 14 : 1 to 22 : 1	:	It's compression ratio varies from 5 : 1 to 8 : 1
3. It uses diesel oil as fuel	:	It uses petrol or power kerosene
4. Only air is sucked in cylinder in suction stroke	:	Mixture of air and fuel sucked in cylinder in suction stroke.
5. It has got fuel injection pump	:	It has got no fuel injection pump
6. Fuel is injected in combustion chamber and ignited due to heat of compression	:	Air fuel mixture is compressed in the combustion chamber where ignited by an electric spark.
7. Thermal efficiency 32 to 38 %	:	Thermal efficiency 25 to 32 %
8. Engine weight per hp is high	:	Engine weight per hp is low
9. Operating cost is low	:	Operating cost is high
10. Compression pressure inside the cylinder varies from 35 to 45 kg/cm ² and temp. is about 500°C	:	Compression pressure varies from 6 to 10 kg.cm ² and temp. is about 260°C

Problems

1. Calculate the BHP of a 4 stroke, 4 cylinder I.C. engine which has cylinder bore = 12.5 cm, stroke length = 15 cm., Crank shaft Speed - 1000 rpm, frictional HP = 30, mean effective pressure = 7 kg/cm²
2. A four cylinder four stroke gas engine has cylinder diameter of 25 cm, stroke bore ratio is 1.8, clearance volume 4500 cm³, engine speed 240 rev/min, mean effective pressure 6.8 kg/cm² and mechanical efficiency is 75 per cent, calculate (1) IHP, (2) BHP, (3) Comp. ratio, (4) Swept volume.
3. A four stroke engine has a mean effective pressure of 7 kg/cm², area of piston is 730 cm², stroke length 45 cm, torque due to break load is 110 kg-meter, fuel consumed per hr. is 4.5 kg and working speed 120 r.p.m. find IHP, BHP, mech. Efficiency and specific fuel consumption.

.....

Exercise No. 3: Study of Four Stroke Cycle Engine

Principle of operation of Internal Combustion Engine

All internal combustion engines used expansive forces of gases by burning fuel within a cylinder. There are two ways in which combustion takes place in the cylinder.

- i. By rapid explosion of air fuel mixture when it is ignited by spark called as constant volume combustion e.g. petrol engine.
- ii. Explosion takes place by slow combustion of injected fuel in the hot compressed air called as constant pressure combustion e.g. Diesel engine.

Working of Four Stroke Cycle Engine

In four stroke cycle engine all events takes place inside the cylinder are completed in four strokes of piston. Valves are provided for inlet and exhaust gases. The cycle is completed in two revolution of the crankshaft or four strokes of piston.

Four Strokes are as follows

1. Suction or Intake Stroke
2. Compression Stroke
3. Power Stroke
4. Exhaust Stroke

1. Suction Stroke

During suction stroke air or mixture of air and fuel is taken in the cylinder through inlet valve opening, which remains open during suction stroke. A sort of vacuums is created in the cylinder due to movement of piston. Exhaust valve remains closed during this stroke.

2. Compression Stroke

The charge taken in the cylinder is compressed to a small volume during this stroke. Both the valves remains closed during this stroke. At the end of the stroke the charge is ignited. Air fuel mixture is ignited by spark plug. If only air is compressed, fuel is injected and it is ignited due to high temperature and pressure at the end of the stroke.

3. Power Stroke

High pressure is developed due to combustion of fuel. It pushed the piston with tremendous amount of force in back ward direction. Power developed in this process is transmitted to crankshaft.

4. Exhaust Stroke

During this stroke exhaust value opens and exhaust gases are removed through valve opening out of the cylinder. Thus it is found that there is one power stroke in a cycle and other three strokes are idle strokes. Thus, the cycle is repeated during working of engine.

.....

Exercise No. 4 :**Study of Fuel supply systems for S. I. Engines****Fuel supply systems in S. I engines**

The fuel supply system of spark ignition engine consists of

1. Fuel Tank
2. Sediment Bowl
3. Fuel Lift Pump
4. Carburetor and
5. Fuel pipes

In some spark ignition engine, the fuel tank is placed above the level of the carburetor. The fuel flows from the fuel tank to the carburetor under the action of gravity. There are one or two filters between the fuel tank and the carburetor. A transparent sediment bowl is also provided to hold the dust and dirt of the fuel. If the tank is below the level of the carburetor, a lift pump is provided in between the tank and the carburetor for forcing fuel from the tank to the carburetor of the engine. The fuel comes from the fuel tank to the sediment bowl and then to the lift pump. From there the fuel goes to the carburetor through suitable pipe. From the carburetor, the fuel goes to the engine cylinder through the inlet manifold of the engine.

Carburetor:

The process of preparing an air-fuel mixture away from the cylinders of an engine is called carburetion and the device in which this process takes place is called carburetor.

Problems

1. An internal combustion engine consumer high speed diesel oil at the rate of 0.5 kg per hour. Calculate the power in terms of kilo watt.
2. A four stroke diesel engine operating at 800 r.p.m. user 0.11 kg of fuel in 4 min. While developing at torque of 7.65 kg meter. Calculate the brake specific fuel consumption.

.....

Exercise No. 5 :**Study of Fuel supply systems for C. I. Engines****Fuel supply system of C.I. Engine**

During engine operation, the fuel is supplied by gravity from fuel tank to the primary filter where coarse impurities are removed. From the primary filter, the fuel is drawn by fuel transfer pump and is delivered to fuel injection pump through second fuel filter. The fuel injection pump supplies fuel under high pressure to the injectors through high pressure pipes. The injection atomize the fuel and inject it into the combustion chamber of the engine. The fuel injection pump is fed with fuel in abundance. The excess fuel is by passed to the intake side of the fuel transfer pump through a relief valve.

The main components of the fuel system in diesel engine are

1. Fuel filter
2. Fuel lift pump
3. Fuel injection pump
4. Atomizers and
5. High pressure pipe

The fuel lift pump lifts the fuel from the tank to the fuel injection pump. Usually the fuel goes from the fuel tank to the first filter, then to fuel lift pump, then to second filter, then to fuel injection pump and then to the atomizers. On some tractors and industrial engines, the fuel system is by gravity and hence no fuel lift pump is provided.

Two conditions are essential for efficiency operation of fuel system

- i. The fuel oil should be clean, free from water, suspended dirt, sand or other foreign matter.
- ii. The fuel injection pump should create proper pressure, so that diesel fuel may be perfectly atomized by injectors and be injected in proper time and in proper quantity in the engine cylinder. Fuel should be filtered before filling the tank also. If these precautions are followed, ninety per cent of diesel engine troubles are eliminated.

Fuel Lift Pump (Feed Pump or Transfer Pump)

It is a pump which transfers fuel from the line to the fuel injection pump. It is mounted on the body of fuel injection pump. It delivers adequate amount of fuel to the injection pump. The pump consists of

1. Body
2. Piston
3. Inlet valve and
4. Pressure valve

The valves are tightly pressed against their seats by springs. The piston is free to slide in the bore. The fuel contained in the space below the piston is forced to flow through secondary fuel filter to the injection pump. At the same time downward movement of the piston creates a depression in the space above the piston which causes the fuel to be drawn in the transfer pump from the fuel tank through the inlet valve and the primary filter.

Fuel Injection Pump

It is a pump which delivers metered quantity of fuel to each cylinder at appropriate time under high pressure.

Tractor engines may use two types of fuel injection pump

- i. Multi element pump and
- ii. Distributor (Rotary) type pump.

.....

Exercise No. 6 :**Study of Air Cleaning and Cooling systems of an engine****Cooling System**

A system which controls the engine temperature is known as cooling system.

Necessity of Cooling

- i. The temperature of the burning gases in the cylinder reaches upto 1500 to 2000 °C, which results in expansion, wear and tear of cylinder.
- ii. Due to very high temperature the film of lubricating oil will get oxidized. This will result in piston deterioration.
- iii. Large temperature difference may results in distortion of engine components.
- iv. Higher temperature also lowers the volumetric efficiency of engine.

For satisfactory performance of engine, it should neither be overheated nor over cooled. Experiments have shown that petrol engine operates best at 180°F, kerosene engine at 200°F and diesel engine at 140°F to 165°F.

Methods of Cooling

- i. Air cooling
- ii. Water Cooling

Air Cooling:

Air-cooled engines are those engines, in which heat is conducted from the working components of the engine to the atmosphere directly. In such engines, cylinders are generally not grouped in a block.

Principle of Air Cooling:

The cylinder of an air-cooled engine has fins to increase the area of contact of air for speedy cooling. The cylinder is normally enclosed in a sheet metal casing called cowling. The flywheel has blades projecting from its face, so that it acts like a fan drawing air through a hole in the cowling and directing a around the finned cylinder. For maintenance of air cooling system, passage of air is kept clean by removing grasses etc. This is done by removing the cowling and cleaning out the dirt etc. by a stiff brush or compressed air. When separate fan is provided the belt tension is to be checked and adjusted if necessary.

Advantages of Air Cooled Engine.

- i. It is simpler in design and construction.
- ii. Water jackets, radiators, water pump thermostat, pipes, houses etc. are not needed.
- iii. It is more compact.
- iv. It is comparatively lighter in weight.

Disadvantages:

- i. There is uneven cooling of the engine parts.
- ii. Engine temperature is generally high during working period.

Water Cooling:

Engine, using water as cooling medium is called water-cooled engines. The liquid is circulated round the cylinders to absorb heat from the cylinder walls. In general, water is used as cooling liquid.

The heated water is conducted through a radiator which helps is cooling the water.

There are three common methods of water-cooling:

- i. Open jacket or hopper method.
- ii. Thermosiphon method.
- iii. Forced circulation method.

Thermosiphon Method:

It consists of radiator, water jacket, fan, and temperature gauge and hose connections. The system is based on the principle that heated water which surrounds the cylinder becomes lighter in weight and it rises upwards in liquid column. Hot water goes to the radiator, where it passes through tubes surrounded by air. Circulation of water takes place due to the reason that water jacket and the radiator are connected at both sides i.e. at the top and the bottom. A fan is driven with the help of a v-belt to suck air through tubes of the radiator unit, cooling radiator water. The disadvantage of the system is that circulation of water is greatly reduced by accumulation of scale or foreign matter in the passage and consequently it causes overheating of the engine.

Forced Circulation Method:

In the method, a water pump is used to force water from the radiator to the water jacket of the engine. After circulating the entire run of water jacket, water comes back to the radiator where it loses its heat by the process of radiation. To maintain the correct engine temperature, a thermostat valve is placed at the outer end of cylinder head. Cooling liquid is by-passed through the water jacket of the engine until the engine attains the desired temperature. Then thermostat valve opens and the by-pass is closed, allowing the water to go to the radiator. The system consists of: (1) Water pump (2) Radiator (3) Fan (4) Fan-belt (5) Thermostat valve (6) Temperature gauge (7) Hosepipe.

Water Pump:

It is a centrifugal type pump. It has a casing and an impeller, mounted on a shaft. The casing is usually made of cast iron. Pump shaft is made of some non-corrosive material. At the end of the shaft, a small pulley is fitted which is driven by a V-belt. Water pump is mounted at the end of the cylinder block between block and the radiator. When the impeller rotates, the water between the impeller blades is thrown outward by centrifugal force and thus water goes to the cylinder under pressure. The pump outlet is connected by a hosepipe to the bottom of the radiator. The impeller shaft is supported on one or more bearings. There is a seal, which prevents leakage of water.

Radiator:

Radiator is a device for cooling the circulating water in the engine. It holds a large volume of water in close contact with a large volume of air, so that heat is transferred from the water to the air easily.

Hot water flows into the radiator at the top and cold water flows out from the bottom. Tubes or passages carry the water from the top of the radiator to the bottom, passing it over a large metal surface. Air flows between the tubes or through the cells at right angles to the downward flowing water. This helps in transferring the heat from the water to the atmosphere. On the basis of fabrication, the radiator is of two types: (a) Tubular type and (b) Cellular type.

Air cleaner

It is a device which filters and removes dust, moisture and other foreign matter from the air before it reaches the engine cylinder.

Air cleaner is usually of two types:

1. Dry type air cleaner and
2. Oil bath type air cleaner

1. Dry type air cleaner: The filtering element in this case is a type of felt. The air passes through the element. The element has got larger surface area so the air speed becomes relatively low and consequently particle or dirt in the air is deposited on or stopped by its surface.

2. Oil bath type air cleaner: In this type of air cleaner, this incoming air impinges upon the surface of the oil, kept in a container in the lower part of the casing. The foreign particles of the air are trapped in the oil and then the air passes through a wire element before reaching the inlet manifold of the engine. The wire element also arrests the remaining dirt particles of the air.

.....

Dept. of Agril. Engg. V.N.M.K.V., Parbhani

Exercise No. 7 :**Study of Lubrication system**

I.C. engine is made up of many moving parts. The continuous movement of two metallic surfaces over each other, there is wearing of parts, generation of heat and loss of power in engine and hence lubrication is must to prevent all these harmful effects.

Types of Lubricants**i) Animal Lubricants**

These are obtained from animal fat. Animal fat does not stand much heat, it becomes waxy and gummy which is not suitable for machines. Also it freeze at lower temperature hence not used.

ii) Vegetable oils

Source of these are oil seed, fruits and plants. They get oxidized very easily. Castor oil has some application on slow moving parts of farm machine.

iii) Mineral lubricants

These are obtained from crude petroleum. This group of lubricants is available in the form of oils and greases. They are the major source to meet the lubrication requirements of the engines and farm machines.

Qualities of good lubricants

- i) It should have sufficient viscosity to keep rubbing surface a-part.
- ii) It should remain stable under changing temperature
- iii) It should keep lubricated parts clean
- iv) Its should not erode metallic surfaces

Purpose of Lubrication**a) Reducing friction effect**

The primary purpose of the lubrication is to reduce friction and wear between tow rubbing surfaces. It also reduces noise produced by the movement of two metal surface over each other.

b) Cooling effect

The heat generated by piston, cylinder and bearings is removed by lubrication. Lubrication creates cooling effect on the engine parts.

c) Sealing effect

The lubricant enters into the gap between cylinder liner, piston and piston rings. Thus it prevents leakage of gases from the engine cylinder.

d) Cleaning effect

Lubrication keeps the engine clean by removing dirt or carbon from inside of the engine.

Engine Lubricating System

The lubricating system of an engine is an arrangement of mechanism and devices which maintains supply of lubricating oil to the rubbing surface of an engine at correct pressure and temperature.

The parts, which require lubrication, are:

- (i) Cylinder walls and piston.
- (ii) Piston pin.
- (iii) Crankshaft and connecting rod bearings.
- (iv) Camshaft bearing.
- (v) Valves and valve operating mechanism.

- (vi) Cooling.
- (vii) Water pump and.
- (viii) Ignition mechanism.

There are three common systems of lubrication used on stationary engines, tractor engines and automobiles:

Splash system (i) forced feed system and (iii) Combination of splash and forced feed system.

1. Splash System

In this system there is an oil trough, provided below the connecting rod. Oil is maintained at a uniform level in the oil trough. This is obtained by maintaining a continuous flow of oil from the oil sump or reservoir into a splash pan. This pan receives its oil supply from the oil sump either by means of a gear pump or by gravity. The dipper is provided at the lower end of the connecting rod which splashes oil out of the pan. The splashing action of oil maintains a fog or mist of oil providing lubrication to inner parts of engine. This system is usually used on single cylinder engine with closed crankcase.

2. Forced feed system

In this system the oil is pumped directly to the crankshaft, connecting rod, piston pin, timing gears and camshaft through suitable paths of oil. Usually the oil first enters the pipes in the crankcase through a positive displacement pump. From this pipe it goes to big end bearing of connecting rod. From there it goes to lubricate the walls, piston and rings. From separate pipe to lubricate timing gears. The excess oil comes back from the cylinder head to the crankcase. The system is commonly used on high speed multi-cylinder engine in tractors, trucks and automobiles.

Combination of Splash and Forced Feed System:

In this system, the engine component, which are subjected to very heavy load are lubricated under forced pressure, such as main bearing, connecting rod bearing and camshaft bearing. The rest of the parts like cylinder liners, cams, tappets etc. are lubricated by splashed oil.

Care and Maintenance of Lubrication System

The following are few suggestions for good lubrication system

1. A good design of oil circulation system should be chosen
2. Correct grade of lubricant ensures long and trouble free service.
3. Oil should be maintained at desired level in the oil chamber
4. Oil should be cleaned regularly and after specified period of use, old filters should be replaced by new filters.
5. Connections, pippins, valves and pressure gauge should be checked regularly.
6. Oil should be changed regularly after specified interval of time. Before putting the new oil, the crankcase should be cleaned and flushed well with flushing oil.
7. Precautions should be taken to keep the oil free from dust and water.

.....

Exercise No. 8 : **Study of Clutch, Gear box and Differential Unit of the Tractor**

(1) Clutch

Clutch is a device, used to connect and disconnect the tractor engine from the transmission gears and drive wheels. Clutch transmits power by means of friction between driving members and driven members.

Necessity of Clutch in a Tractor

Clutch in a tractor is essential for the following reasons

- i. Engine needs cranking by any suitable device. For easy cranking, the engine is disconnected from the rest of the transmission unit by a suitable clutch. After starting the engine, the clutch is engaged to transmit power from the engine to the gear box.
- ii. In order to change the gears, the gear box must be kept free from the engine power, otherwise the gear teeth will be damaged and engagement of gear will not be perfect. This work is done by a clutch.
- iii. When the belt pulley of the tractor works in the field it need to be stopped without stopping the engine. This is done by a clutch.

Essential Features of a Good Clutch

- i. It should have good ability of taking load without dragging and chattering.
- ii. It should have higher capacity to transmit maximum power without slipping.
- iii. Friction surface should be highly resistant to heat effect.
- iv. The control by hand lever or pedal lever should be easy.

Types of Clutch

Clutches are mainly or three types

1. Friction Clutch
2. Dog Clutch
3. Fluid coupling

Friction clutch is popular in four wheel tractors. Fluid clutch is also used in some tractors these days. Dog clutch is mostly used in power tillers. Friction clutch may be subdivided into three classes:

- a. Single plate clutch or single disc clutch
- b. Multiple plate clutch or multiple disc clutch and
- c. Cone clutch

Friction Clutch

Friction clutch produces gripping action, by utilizing the frictional force between two surfaces. These surfaces are pressed together to transmit power.

While starting the engine, the clutch pedal is depressed. After the start of the engine, the clutch pedal is slowly released to increase the pressure gradually on frictional surfaces until there is no slip. Thus the driven plate is gripped firmly to the driving plate. Transmission of power depends upon the kind of material used for the friction members and intensity of the force, pressing them together.

Single Plate Clutch

This may be called single disc clutch. It consists to:

1. Pressure Plate
2. Clutch Plate
3. Springs and
4. Release fingers

There is only one clutch plate in this type. The clutch plate is pressed against the flywheel of the engine by means of spring loaded pressure plate. When the pedal of the clutch is depressed, the pressure plate is pushed back by the release fingers. This releases the pressure from the clutch plate. Then the clutch plate stops rotating but the flywheel continues to rotate. When the clutch pedal is released, the pressure plate forces the clutch plate against flywheel to cause the clutch plate and the flywheel to turn together as one unit. Thus the power of the engine goes to the gear box for onward transmission to rear wheels.

Multiple Plate Clutch

This may be called multiple disc clutch. It has got a number of thin metal plates, arranged alternately to work as driving and driven members. One set is attached to the flywheel and the other set is attached to the clutch shaft. If the plates are pressed together, the clutch is said to be engaged and the power is transmitted from the engine to the gear box for onward transmission to the rear wheels. Thus pressure is obtained by a set of heavy springs, fitted together in a housing.

Engagement and disengagement of this type of clutch is very smooth due to larger surface area of friction members.

Dog Clutch

It is a simple clutch having square jaws which are used to drive a shaft in either direction. It is mostly used in power tillers.

(2) Gear

A tractor engine at high speed, but the rear wheel of the tractor requires power and high torque. That's why it becomes essential to reduce to engine speed and increase the torque available at the rear wheels of tractor because

$$HP = \frac{2 \pi NT}{4500}$$

where,

T - torque (kg.m) and

N - rev/min.

If the engine hp is constant, it is obvious that for higher torque at wheels, low speed is required and vice versa. So the gear box is fitted between engine and rear wheel for variable torque and speed. This is done by suitable design of gear and shafts. Speed varies according to the field requirements and so a number of gear ratios are provided to suit the varying conditions. Gears are usually made of alloy steel. As the tractor has to transmit heavy torque all the time, best quality lubricants free from sediments, grit, alkali and moisture, is used for lubrication purpose. SAE 90 oil is generally recommended for gear box. Common gears used on tractors are of two types:

- i. Selective sliding type
- ii. Constant mesh type

Selective Sliding Type

The gear box consists of

- i. gear housing
- ii. gear shifting lever
- iii. main shaft or input shaft
- iv. output shaft and
- v. layshaft or countershaft

A number of gears are mounted on these shafts. The main shaft is directly connected to the clutch and carries gears. The gears are liable to slide. The gears are shifted with the help of shifting lever and shifting fork.

The gears are shifted along the shaft, to which they are splined to engage with another gear as and when desired to connect the power train. The gears are of different diameters having different number of teeth. Speed is reduced in proportion to the number of teeth provided on the gears.

Constant Mesh Type

These gears are always in mesh. Usually the gears are helical in shape. The transmission is put into operation by engagement of shifting couplings which slide along the splines on the countershaft and the output shaft of the gear box.

(3) Differential and final drive of a tractor**Differential**

Differential unit is a special arrangement of gears to permit one of the rear wheels of the tractor to rotate slower or faster than the other. While turning the tractor on a curved path, the inner wheel has to travel lesser distance than the outer wheel. The inner wheel requires lesser power than the outer wheel, this condition is fulfilled by differential unit, which permits one of the rear wheels of the tractor to move faster than the other at the turning point. The output shaft coming from the gear box is provided with a bevel pinion at the end of the shaft. The bevel pinion is in mesh with a large bevel wheel known as crown wheel. The main functions of crown wheel assembly are

- i. to transmit power through right angle drive to suit the tractor wheels
- ii. to reduce the speed of rotation

The differential unit consists of

- i. Differential casing
- ii. Differential pinion
- iii. Crown wheel
- iv. Half shaft and
- v. Bevel gear

The differential casing is rigidly attached with the crown wheel and moves like one unit. Two pinions are provided inside the differential casing such they are carried round by the crown wheel but they are free to rotate also on their own shaft or stud. There are two or more bevel gears in mesh with differential pinion. One bevel pinion is at the end of each half shaft, which goes to the tractor rear wheel. Thus instead of crown wheel being keyed directly to a solid shaft between the tractor wheels, the drive is taken back from the indirect route through differential casing, differential pinion and half shaft the tractor. When the tractor is moving in a straight line, the differential pinion do not rotate on the stub shaft but are solid with the differential casing. They drive the two bevel gears at the same speed and in the same direction as the casing and the crown wheel.

Each differential pinion can move in two planes simultaneously. when it is carried round by the casing, it drives the half shaft in the same direction but when it is rotated on its own shaft, it drives them in opposite direction i.e. rotation of differential pinion adds motion to one shaft and subtracts motion from the other shaft.

Differential Lock

Differential lock is a device to join both half axles of the tractor so that even if one wheel is under less resistance, the tractor comes out from the mud, etc. as both wheels move with the same speed and apply equal traction.

Final Drive

Final drive is a gear reduction unit in the power trains between the differential and the drive wheels. Final drive transmits the power finally to the rear axle and the wheels. The tractor rear wheels are not directly attached to the half shafts but the drive is taken through a pair of spur gears. Each half shaft terminates in a small gear which meshes with a large gear called bull gear. The bull gear is mounted on the shaft, carrying the tractor gear wheel. The device for final speed reduction, suitable for tractor rear wheels is known as final drive mechanism.

.....

Exercise No. 9 :**Study of Primary Tillage Implements:
Mould board plough and Disc plough**

A mould board plough is very common implement used for primary tillage operations. The plough performs several functions at a time.

Function:

1) Cutting the furrow slice, 2) Lifting soil, 3) Turnings furrow slice and 4) Pulverizing soil.

Components:

M. B. plough consists of: a) Share, b) Mould board, c) Land side, d) Frog and e) Tail piece.

Share:

It is that part of the plough bottom, which penetrates into the soil and makes a horizontal cut below the surface.

Mould Board:

It is the curved part, which lifts and turns the furrow slice.

Land Side:

It is the flat part, which bears against and transmits the rear side lateral thrust of the plough bottom to the furrow wall.

Frog:

It is the part to which other components of the plough bottom are attached.

Tail Piece:

It is an adjustable extension, which can be fastened to the rear of a mould board to help in turning a furrow slice.

A. Shares:

It penetrates into the soil and makes a horizontal cut below the soil surface. It is a sharp, well-polished and pointed component. Different portions of the share are called by different names as:

1) Share point 2) Cutting edge 3) Wing of share 4) Gunnel 5) Cleavage edge and 6) Wing bearing.

1. Share Point:

It is the forward end of the cutting edge, which actually penetrates into the soil.

2. Cutting Edge:

It is the front edge of the share, which makes horizontal cut in the soil. It is beveled to some distance.

3. Wing of Share:

It is the outer end of the cutting edge of the share. It supports the plough bottom.

4. Gunnel:

It is the vertical face of the share, which slides along the furrow wall. It takes the side thrust of the soil and supports the plough bottom against the furrow wall.

5. Cleavage Edge:

It is the edge of the share which forms joint between mould board and share on the frog.

6. Wing Bearing:

It is the level portion of the wing of the share, providing a bearing for the outer corner of the plough bottom.

Material of Share:

The share is made of chilled cast iron or steel. The steel mainly contains about 0.70 to 0.80 % carbon and about 0.50 to 0.80 % manganese besides other minor elements.

B. Mouldboard:

The mouldboard is that part of the plough, which receives the furrow slice from the share. It lifts, turns and breaks the furrow slice. To suit different soil conditions and crop requirements, mould board has been designed in different shapes.

C. Landside:

It is the flat plate, which bears against and transmits lateral thrust of the plough bottom to the furrow wall. It helps to resist the side pressure exerted by the furrow slice on the mould board. It also helps in stabilizing the plough while it is an operation. Landside is fastened to the frog with the help of plough bolts. The rear bottom end of the landside is known as heel, which rubs against the furrow sole.

D. Frog:

Frog is that part of the plough bottom to which the other components of the plough bottom is attached. It is an irregular piece of metal. It may be made of cast iron for cast iron ploughs or it may be welded steel for steel ploughs.

E. Tail Piece:

It is an important extension of mould board which help is turning a furrow slice.

1. Indigenous Ploughs

It is one of the most common implements used by Indian Farmers. The main parts of the plough are

- | | |
|-----------|-------------|
| 1) Body | 2) Shoe |
| 3) Share | 4) Beam and |
| 5) Handle | |

The body is the main part of the plough to which the shoe, beam and handle are attach. The shear is the working part of the plough and is attached to the shoe. The shoe also supports and stabilizes the plough at the required depth. The beam is a long wooden piece which connected the main body of the plough to the Yoke. A wooden piece which is attached vertically to the body to enable the operator to control the plough is called the handle.

2. Mould Board Ploughs

These ploughs are used in areas where there is sufficient rainfall to produce to good crop. It is also used to turn under the heavy growth of green manure crop to the proper decay and additions of humus to the soil.

Types of Mould Board Ploughs**1. One way or Two way ploughs**

Most of the walking type mould board ploughs are one way ploughs, that is they are designed to throw the furrow slice to only one side in the direction of the motion. Two way ploughs are suitable for terraced land of hilly tracts and have the advantages that they do not upset the slope of the land nor leave dead or back furrows in the middle of narrow fields. This is because the two bottoms are used alternately and the furrow-slices are thrown on the same side. The two way plough is also useful for ploughing irrigated land where it is required that the land be left without the depression of the dead furrows and ridges of back furrows. Some of the two way ploughs have a single bottom but the provision is made to change the direction of throw of furrow slice at the end of the plot where the bullocks turn. Such a plough is also knows as Turn Wrest Plough.

2. Left hand or Right hand Ploughs

These names refer to the direction of the throw of the furrow slice. Most of the mould board ploughs are right. Left hand type ploughs are rare in India because bullocks are trained to take turn on their left while ploughing.

Plough Sizes

The size of the mould board is expressed by the width of furrow that it is designed to cut. It can be measured by measuring perpendicular distance from the wing of share to the land side.

Plough Adjustment

For proper penetration and efficient work by the mould board plough, some clearance is provided in the plough this clearance is called "Suction" of the plough.

Vertical Suction or Clearance is the maximum clearance under the landside and horizontal surface in the working position. It is the vertical distance from the ground, measured at the junction point of share and landside. It helps the plough to penetrating into the maximum horizontal clearance between the landside and the furrow slice. This clearance varies according to the size of the plough to maintain proper width of the furrow.

Study of disc plough

A disk plough is one of which cuts, turns and in some cases breaks furrow slices by means of separately mounted large steel disks. It works well in the conditions where m.b. plough does not work satisfactorily.

Advantages of Disk Plough

1. The soil which is too hard and dry for ploughing with m.b. plough can be ploughed to required depth by disk plough.
2. It works well in sticky soils than m.b. plough.
3. It is more useful for deep ploughing.
4. It can be used safely in stony and stumpy soil without much danger of breakage.
5. It works well in loose soils also without much clogging.

Disadvantages

1. It is not suitable for covering surface bush and weeds as that of m.b. plough
2. It leaves soil more in rough and cloddy conditions.
3. It is much heavier than m.b. plough for equal capacities

Terms Connected with Disk Plough**1. Disk**

It is a circular, concave revolving steel plate use for cutting and inverting the soil.

2. Disk Angle

It is the angle of which place of the cutting edge of the disk is inclined to the direction of travel. This angle of good plough varies between 42° & 45° .

3. Tilt Angle

It is the angle at which the plane of cutting edge of the disk is inclined to a vertical line. It varies between 15° & 25° .

4. Concavity

It is the depth measured at the centre of disk by placing its concave side on the level surface.

A. Standard Disk Plough

It consists of steel disk of 60 to 80 cm diameter set at certain angle to the direction of travel. Disk is made of heat treated steel $1/16''$ to $3/8''$ thick edge of which is well sharpened. Concavity varies with diameter of a disk (Approximate values of concavity being 3" for 24" dia disk and 6.5" for a 18" dia. disk).

Weight of plough :	Tractor drawn	-	180 to 540 kg
	Animal drawn	-	32 kg.

The scraper is provided to remove soil that tends to stick to working surface of the disk. Each disk revolves on a stub axle in a thrust bearing, carried at the lower end of a strong stand bolted to the plough beam.

Mounted type

In this side thrust is taken by the wheels of tractor or sometimes rear wheel is fitted to take side thrust.

Trailed type

Side thrust is taken by the furrow wheel.

B. Vertical Disk Plough

It combines the principles of regular disk plough and disk harrow and used in shallow soil working in the soil (3" to 4" deep). It consists of frame, wheel arrangements, depth adjusting device are as Std. disk plough but the disks are fitted on single shaft and turn as on unit.

The dia of disk is smaller and varies between 50 to 60 cm. Disk angle ranges between 35° to 55° . There may be 2 to 32 disks spaced about 30 cm apart. All disks are fixed to throw soil in one direction. This plough is preferred in wheat growing areas.

Plough Adjustments

Various adjustments done on disk plough are for controlling depth or width of ploughing and to increase pulverization. These are achieved as under.

1. By Decreasing the tilt angle penetration is improved in standard plough
2. By increasing the disk angle penetration is improved but width of cut is reduced.
3. By adding weights to the plough penetration is increased.
4. The disk should be well polished and sharp
5. The plough wheels should be properly adjusted to keep plough operating level
6. The angle between the frame and land wheel axle be adjusted for required width or cut.

Defect	Reason	Remedy
1. Low penetration	i) Blunt disk ii) Plough too light iii) More tilt angle	Sharpen the inner edge of the disk. Put additional load Set the tilt angle
2. Heavy draft	i) Blunt disk ii) Furrow too wide	Sharpen the edge Reduce tilt angle
3. Excessive side draft	i) Improper hitching	Hitch properly
4. Less scouring by disk	i) Scraper not properly set	Adjust the scraper correctly
5. Uneven furrows	i) Disk angle changing ii) Loose bearings	Set the disk angle Set the bearing

Problems

1. A farmer purchased a 35 HP wheel type tractor at a total cost of Rs.3,50,000 and three bottom plough with 30 cm bottom width at Rs.6000 only. The fuel consumption of the tractor was 6 lit/hr at the ploughing speed of 5 kmph. a) Calculate the area ploughed per hr. b) Determine cost of ploughing per hectare. Make necessary assumption if any.
2. Determine the horse power required to pull a four bottom 30 cm plough working to depth of 15 cm. The tractor is operating at a speed of 6 kmph. The soil resistance is 0.7 kg/cm^2 .
3. Total draft of four bottom 40 cm M.B. plough when ploughing 17.5 cm deep at 5.5 km/hr speed is 1700 kg. a) Calculate the unit draft in kg/cm^2 b) What is actual power requirement? c) If field efficiency is 75 % what is the rate of doing work in ha/hr.

Exercise No. 10 :**Study of secondary tillage implements- Harrows and Cultivators.****Interculturing:**

Breaking the upper surface of the soil, uprooting the weeds (unwanted plants), aerating the soil, thereby promoting the activities of microorganisms and making a good mulch, so that the moisture inside the crop field is properly retained from evaporation.

(1) Harrow

Harrows are used to break the clods, pulverize the soil and cut the weed at the time of preparing seed beds. Some of the important functions are to prepare the seed bed, to cover seeds, to stir and spread FYM and fertilizers in the fields, to aerate the soil and to control the weeds. There are several types of harrows in use such as

1. Disc Harrow
2. Spring Tooth Harrow
3. Spike Tooth Harrow and
4. Other Harrows (e.g. peg tooth harrow)

1. Disc Harrow

It is a harrow which performs the harrowing operations by means of a set of a number of sets of rotating steel disc, each set being mounted on a common shaft. Disc harrow are of two types, viz. tractor drawn and bullock drawn.

Tractor Drawn Disc Harrow

Disc harrow is found very suitable for hard ground full of stalks and grasses. It cuts the lump of soil clods and roots. Discs are mounted on one, two or more axles which may be set at a variable angle to the line of motion. As the harrow is pulled ahead, the disc rotate on the ground. Depending upon the arrangements of discs, disc harrows are divided into three classes.

- 1) Single action
- 2) Double action (Tandem) &
- 3) Offset

a. Single Action Disc Harrow

It is a harrow with two gangs plough end to end, which throw the soil in opposite direction. The discs are arranged in such a way that right side gang throws the soil towards right and left side gang throws the soil towards left.

b. Double action (Tandem) Disc Harrow

It is a disc harrow consisting of four gangs in which a set of two gangs follow behinds the set of the other two gangs, arranged in such a way that the front and back gangs throw the soil in opposite directions. It can be said that the two front gangs throw the soil outwards while the two rear gangs shift the soil inwards. Thus the entries field is worked twice in each trip.

c. Offset Disc Harrow

It has got only gangs, fitted one behind the other. The soil is thrown in both directions because discs of gangs face in opposite directions. It is very useful for orchards and gardens. The line of the pull is not in the middle hence it is called offset disc harrow. In offset disc harrow basic principle is that side thrust against the front gang is opposed by the side thrust of the rear gang.

Components of Disc Harrow

A disc harrow mainly consists of disc gang, gang both or arbor bolt, gang control lever, spool or spacers, bearings, transport wheels, scraper and weight box.

i. Disc

It is a circular, concave revolving steel plate used for cutting and inverting the soil.

ii. Gang

Each set of discs which are mounted on a common shaft is called gang.

iii. Gang bolt or Arbor bolt

It is a long heavy bar of square or circular section threaded at one end and square headed at the other end. A set of disc are mounted on this gang bolt.

iv. Gang Control Lever

A lever which operates the angle mechanism of the disc harrow is called gang control lever.

v. Spool or Spacer

The flanged tube mounted on the gang bolt between every two discs to prevent the lateral movement of the disc on the shaft is called spool or spacer.

vi. Bearing

Bearing is essential to counteract the end thrust of the gangs due to soil thrust.

vii. Transport wheel

These wheels are provided for transport work on roads.

viii. Scraper

It prevents the discs from clogging. It remove the soil sticking to the concave side of the discs.

ix. Weight box

It puts additional weight on the implements there by it also helps in increasing the penetration of the disc in the soil.

Penetration of Disc Harrow

It is achieved by any one of the following ways

1. by increasing the gang angle
2. by adding additional weight,
3. by lowering the hitch point
4. by using the sharp edged discs of small diameter and lesser concavity
5. by regulating the optimum speed.

Care and Maintenance of Disc Harrow:

- i. Bearing must be thoroughly greased at regular intervals.
- ii. All the nuts and bolts must be checked daily before taking the implement to the field.
- iii. Blunt edges of the discs should be sharpened regularly.
- iv. During slack season, the worn parts including bearings should be fully replaced.
- v. It is better to coat the outer and inner surfaces of the discs when the harrow is lying without use in slack season.

2. Animal Drawn Disc Harrow:

Disc harrow is used for breaking clods while preparing seed beds. It has usually six or eight discs fixed in two gangs, each gang has three or four discs. There is a strong frame made of mild steel, on which gangs with the disc are mounted. As operator's seat is also provided on the frame. Usually transport wheels are provided for easy movement of the harrow from place to place. The size of the harrow is determined by the maximum width of cut of the soil. The disc harrow varies between 80 to 100 kg only. The disc harrow mainly consists of : (i) Disc (ii) Gang frame (iii) Beam (iv) Gang angle mechanism (v) scraper (vi) Spacer (spool) (vii) Clevis (viii) Axle (ix) Middle type and (x) Bearings.

3. Spring Tooth Harrow

It is a harrow with flexible teeth suitable to work in hard and stony soils. Spring tooth harrow is fitted with springs, having loops of elliptical shape. It gives spring action in working conditions. This type of harrow mainly consists of teeth, tooth bars, clamps, frame, clevis, lever and links. The spring steel teeth are fastened to the tooth bars by tooth clamps.

4. Spike Tooth Harrow

It is a harrow with peg shaped teeth of diamond cross section attached to a rectangular frame. It is used to break clods, stir the soil, uproot the weeds, level the ground, break the soil crust, and cover the seeds. Its principle use is to smoothen & level the soil directly after ploughing. Spike tooth type harrows may be of either rigid type or flexible type. The animal drawn spike tooth harrows are usually of rigid type. The tractor drawn harrows are usually of flexible type.

Spike tooth mainly consists of teeth, tooth bars, clamps, guard braces, levers and hooks. The teeth are made of hardened steel. Tooth bars are made of wood or steel. All teeth are fastened rigidly to the tooth bar. Clamps are used to fasten teeth to the tooth bars tightly so as not to be loose while in operations.

(2) Cultivators

It is an implement for inter cultivation with laterally adjustable tines or discs to work between crop rows. This can be used for seedbed preparation and for sowing with seeding attachment. The tines may have provision for vertical adjustments also.

The cultivator can be: 1) Disc cultivator, 2) Rotary cultivator, 3) Tine cultivator.

1. **Disc cultivator:** It is a cultivator fitted with discs.
2. **Rotary cultivator:** It is a cultivator with tines or blades mounted on a power driven horizontal shaft.
3. **Tine cultivator:** It is a cultivator fitted with tines having shovels.

The cultivator stirs the soil, and breaks the clods. The tines fitted on the frame of the cultivator enter deeply in the soil. A cultivator performs functions intermediate between those of plough and the harrow. Destruction of weeds is the primary function of a cultivator. The following are a few important functions performed by a cultivator:

- i) Intercultural the fields.
- ii) Destroy the weeds in the field.
- iii) Aerate the soil for proper growth of crops.
- iv) Conserve moisture by preparing mulch on the surface.
- v) To sow seeds when it is provided with sowing attachments.
- vi) To prevent surface evaporation and encourage rapid infiltration of rain water into the soil.

Depending upon the type of power available for the implement, the cultivator can be classified as 1) Tractor drawn 2) Animal drawn.

1. **Tractor Drawn Cultivator:** It may be: i) Trailed ii) Mounted.

i. Trailed Type Cultivator:

It consists of a main frame, which carries number of cross members to which tines are fitted at the forward end of the cultivator. There is a hitch arrangement for hitching purpose. A pair of wheels is provided in the cultivator. The lift is operated by both wheels simultaneously so that draft remains even and uniform. The height of the hitch is adjusted so that main frame remains horizontal over a range of depth setting. The tines in each row

are spaced widely to allow free passage of the soil and trash around them. The tines in subsequent rows are staggered so that the implement can cover the entire width nicely. The depth of working is set roughly by adjusting the tine in their clamps and the final depth control is done by a screw lever. Usually the types are damaged due to turning the implement at the headland without lifting it up. Care should be taken to lift the tines off the ground before turning.

ii. **Mounted Cultivator:**

Tractors fitted with hydraulic lift operate the mounted type cultivators. A rectangular frame of angle iron is mounted on three point hydraulic linkage of the tractor. The cross members carry the tines in two staggered lines. For actual cutting the soil, different types of shovels and sweeps are used. A few important shovels and sweeps are: (a) Single point shovel (b) Double point shovel (c) Sphear head shovel (d) Sweep (e) Half sweep (f) Furrow type.

Depending upon the type of soil and crop, shovels are chosen for use on the cultivators. Usually tractor drawn cultivators are of two types, depending upon the flexibility and rigidity of tines: (i) Cultivator with spring loaded tines (ii) Cultivator with rigid tynes.

Cultivator with Spring Loaded Tynes

A tyne hinged to the frame and loaded with a spring so that its swings back when an obstacle is encountered is called spring loaded tyne. Each of the tyne of this type of cultivator is provided with two heavy coil springs. On passing over the obstruction, the tynes are automatically reset and work continues without interruption.

This type of cultivator is particularly recommended for soil which is embedded with stones or stumps. The cultivator may be fitted with 7, 9, 11, 13 tynes or more depending upon the requirement.

Cultivator with rigid tynes

Rigid tynes of the cultivator are those which do not deflect during the work in the field.

Problems

1. How many acres can be covered by a harrow of width 1.5 m in a day of 8 hrs with bullock power? The speed of the bullocks it to be assumed. If each spike tooth harrow is giving 1 kg resistance when there are 50 spikes what HP would be necessary for the bullocks to pull the harrow with the assumed speed?
2. A five tyne cultivator having tynes spaced 8 cm a part and working to a depth of 5 cm is running at a speed of 3 kmph. There is a time loss of 10 per cent while turning. Calculate the time required to cultivate per hectare. If the resistance of the soil is 0.6 kg/cm². What would be the maximum draft and HP required when the width of each furrow is 5 cm?

.....

Exercise No. 11 :
Study of inter-culturing Tools and Implements -
Manual and Animal drawn

The main objective of weed control are to improve the soil conditions for heal their growth of plant. Weeds growing along with crops complete for moisture, light and nutrients. Hence, it is essential to remove them.

Following are some of the weeding devices used by the farmers.

Type of weeding tools and implements :

- (1) Traditional hand tools.
- (2) Traditional and Improved hoes.
- (3) Wheel hoes.
- (4) Animal drawn multi purpose hoe.
- (5) Tractor drawn interculture equipment.

(1) Traditional hand tools :

(i) Khurpi : Khurpi is a traditional hand tools and made by local artisans for the use on small and marginal farmers. Khurpi is used in India may vary in their size, shape and weight, but they have common basic part i.e. a cutting blade and a small wooden handle for the grip. The khurpi with a long narrow blade is preferred for weeding around the flower plants, broadcasted crops and vegetable crops. However, a man can weed out about 0.025 hectare in a day under normal condition.

(2) Traditional and Improved hoes :

The hoe is a versatile form of implements used for many operations i.e. seed bed preparation, ridge making, channel shaping and weeding. It is also for removing plant roots, harvesting root crops and thinning drilled crops.

The two common types of hoe used by Indian farmers are :

- (i) Hand hoes (ii) Animal drawn hoes.

Hand hoes are used to cultivate very small area of land by human labour. Among the indigenous type of hand hoes, the Kodali (narrow spade) is most popular one.

(i) Kodali : Kodali is similar to a phawara (broad spade), the difference being that instead of a wide thin cutting blade, a narrow long pointed thicker section blade is attached to the handle. The person working with it has to bend his body. It is used for inter cultivating maize and sugarcane crops, and for earthing up the potato crops sown in line. About 0.04 hectare can be covered in a day by one man.

(ii) Improved hand hoe : An improved hand hoe is operated in the standing position. It is provided with the long handle fitted in the middle of the cutting blade. One end of the blade is about 10 cm wide sharp edge and the other end is pointed narrow one for making small furrows. It can be used for cultivating and weeding very close to the individual plant.

(iii) The Grubber : The grubber is a manual pull type hoe suitable for weeding and inter culture of up land row crops in black cotton soil region. It is provided with three blades and the field capacity is 1/200 ha. per hour.

(iv) Rotary paddy weeder : Rotary paddy weeder is best suited for uprooting the weed and burying them into soil. The operator moves the tools forward and backward in narrow rows of paddy crops. It gives higher output and drudgery of the operator is considerably reduced.

(3) The wheel hoe :

The wheel hoe is another implement which is used for cultivating the land between rows. It consists of a wheel, two handles and a type to place the cutting tool on. Either a reversible shovel or a three prong fork or rake or sweep is used as a cutting tool, depending upon the weed and moisture condition. A man operates the hoe in standing position by pushing through a short length each time. In a working day, 0.04 hectare can be covered.

(4) Animal drawn hoe :

Animal drawn weeding implements are pulled either by single animal or a pair of animal. These implements may either be single row type or multi row unit. The three type cultivator or 'Triphali', Akola hoe, Bardole hoe or two 'Blade hoe' are most popular implements in different region for row crop interculture operations. It is essential to provide wider spacing (above 30 cm) for movement of animals and implements if animal drawn weeders are to be used.

The main parts of the blade hoe are : (i) Head piece (ii) Prong (iii) blade (iv) handle and (v) beam. The number of cutting blades on these hoes may be one or more. The prong make an angle of about 45 ° downward with the horizontal plane. At the end of each prong, the blade is attached. It loosens the upper surface of the soil and is generally used for interculturing sorghum, cotton, groundnut and other *kharif* crops. The hoe width is maintained between 25 and 75 cm depending upon the size of the bullocks and types of soil.

.....

Exercise No. 12 :**Study of Seed-cum-Fertilizer drill****Seed Drill:**

Seed drill is a machine for placing the seeds in a continuous flow in a furrow at uniform rate and at controlled depth with or without the arrangement of covering them with soil.

Function of Seed Drill: Seed drill performs the following functions:

- i. To carry the seeds.
- ii. To open furrow to a uniform depth.
- iii. To meter the seeds.
- iv. To place the seed in furrows in an acceptable pattern.
- v. To cover the seeds and compact the soil around the seed.

Seed-cum-fertilizer Drill:

Seed drills, fitted with fertilizer dropping attachment, distribute the fertilizer uniformly on the ground. It is called seed cum fertilizer drill. Such a drill has a large seed box, which is divided length-wise into two compartments, one for seeds and another for fertilizers. Seed drill may be classified as: i. Bullock drawn ii. Tractor drawn.

Depending upon the method of metering the seeds, bullock drawn seed drill can be further divided into two groups. Those in which seeds are dropped (a) by hand, (b) mechanically. There are a number of bullock drawn implements, which are used for sowing seeds in which seeds are dropped by hand. The most popular implement is three tined cultivator with seeding attachment. In different parts of the country it is made in different sizes and shapes.

Components of Seed Drill:

A seed drill with mechanical seed metering device mainly consists of: (i) Frame (ii) Seed box (iii) Seed metering mechanism (iv) Furrow openers (v) Covering device (vi) Transport wheels.

Frame:

The frame is usually made of angle iron with suitable braces and brackets. The frame is strong enough to withstand all types of loads in working condition.

Seed Box:

It may be made of mild steel sheet or galvanized iron with a suitable cover. A small agitator is sometimes provided to prevent clogging of seeds.

Covering Device:

It is a device to refill a furrow after the seed has been placed in it. Covering the seeds are usually done by patta, chains, drags, packers, rollers or press wheels, designed in various sizes and shapes.

Transport Wheel:

There are two wheels fitted on the main axle. Some seed drills have got pneumatic wheels also. The wheels have suitable attachments to transmit power to operate seed dropping mechanism.

SEED METERING MECHANISM

The mechanism of a seed drill or fertilizer distributor which deliver seeds or fertilizers from the hopper at selected rates is called Seed metering mechanism, Seed metering mechanism may be of several types:

1. Fluted feed type
2. Internal double run type
3. Cup feed type
4. Cell feed mechanism
5. Brush feed mechanism
6. Auger feed mechanism
7. Picker wheel mechanism
8. Star wheel mechanism

Exercise No. 13 :**Study of Calibration of Seed Drill****Calibration of seed drill and seed-cum fertilizer drill**

The procedure of testing the seed drill for correct seed rate is called Calibration of seed drill. It is necessary to calibrate the seed drill before putting it in actual use to find the desired seed rate. Calibration is done to get a predetermined seed rate of the machine. Before using the seed drill or seed-cum fertilizer drill in the field, it is calibrated.

The following steps are followed for calibration of seed drill or seed-cum fertilizer drill.

1. Determine the nominal width (W) of drill.

$$W = M \times S$$

where M is the number of furrow openers and S is the spacing between the openers in metre and W is in metre.

2. Find the length of a strip (L) having nominal width W necessary to cover 1/25th of a hectare.

$$L = 10000 / 25W = 400/W \text{ metre}$$

3. Determine the number of revolutions (N) the ground wheel has to make to cover the length of the strip (L).

$$\pi DN = 10000/25W$$

where D is diameter of ground wheel in metre

$$\text{or } N = 10000/25W\pi D = 400/ W\pi D \text{ rev /min}$$

4. Jack up the drill so that the ground wheels turn freely. Make a mark on the drive wheel and a corresponding mark at a convenient place on the body of the drill to help in counting the revolutions of the drive wheel.

5. Put selected seed and fertilizer in the respective hoppers. Place a sack or a container under each boot for seeds and fertilizers.

6. Set the rate control adjustment for the seed and the fertilizer for maximum drilling. Mark this position on the control for reference.

7. Engage the clutch or on-off adjustment for the hoppers and rotate the drive wheel at the speed N

$$N = 400/ W\pi D \text{ rev /min}$$

8. Weigh the quantity of seed and fertilizer, dropped from each opener and record on the data sheet.

9. Calculate the seed and fertilizer, dropped in kg/hectare and record on the data sheet. 10. Repeat the process by suitable adjusting the rate control till desired rate of seed and fertilizer drop is obtained.

Problems

1. Calculate the cost of seeding 1 hectare of land with bullock drawn seed drill of 5 x 22 cm size. The speed of bullock is 3 kmph. Hire charge of bullock is Rs. 150 per pair hire charges of seed drill Rs. 75 per day and wage of operator Rs. 50 per day of 8 hrs.

2. Calculate the time required for sowing 1.6 hectare of land by five furrows seed drill going 12.5 cm deep. the speed of seed drill is 3.2 kmph and pressure exerted by the soil on the seed drill is 0.42 kg/cm². The space between furrow openers is 10 cm and loss in turning is 10 per cent.

3. The following results were obtained while calibrating a seed drill. Calculate the seed rate per hectare
 - a) No. of furrows = 10
 - b) Spacing between furrows = 20 cm
 - c) Diameter of drive wheel = 1.5 m
 - d) RPM = 500
 - e) Seed collected = 20 kg.

Dept. of Agril. Engg. V.N.M.K.V., Palahalli

Exercise No. 14 :**Study of Sprayers and Dusters****Sprayers:**

Sprayer is a machine to apply fluids in the form of droplets. Sprayer is used for the following purposes:

- 1) Application of herbicides to remove weeds.
- 2) Application of fungicides to minimize fungus discuses.
- 3) Application of insecticides to control insect pests.
- 4) Application of micronutrients on the plants.

The main functions of sprayer are:

1. To break the liquid into droplets of effective size.
2. To distribute them uniformly over the plants.
3. To regulate the amount of liquid to avoid excessive application.

Desirable Quality of Sprayers:

- a. The sprayer should produces a steady stream of spray materials in the desired fineness of the particle so that the plants to be treated may be covered uniformly.
- b. It should deliver the liquid at sufficient pressure so that it reaches all the foliage and spreads entirely over the sprayed surface.
- c. It should be light in weight, sufficiently strong, easily workable and repairable.

Basic Components of Sprayer:

Components of a sprayer are as follows:

- | | | |
|----------------|-----------------------|-----------------|
| 1. Nozzle body | 6. Filter | 11. Nozzle Disc |
| 2. Nozzle cap | 7. Over-Flow Pipe | 12. Nozzle Boss |
| 3. Swirl plate | 8. Relief Valve | 13. Nozzle tip |
| 4. Spray gun | 9. Pressure Regulator | 14. Spray lance |
| 5. Spray boom | 10. Cut-off Valve | |

1. **Nozzle Body:** It is the main component on which other components of a nozzle fit.
2. **Nozzle Cap:** It is a component which retains the assembled parts in or on a nozzle body. The nozzle disc or tip may be integral with the cap.
3. **Swirl Plate:** It is the part of a cone nozzle which imparts rotation to liquid passing through it.
4. **Spray Gun:** It is a spray lance from which the spray is readily adjustable during the operation.
5. **Spray Boom:** It is a spray lance with spray nozzles fitted to a head, mounted at right angles to the lance.
6. **Filter:** It is a component to remove suspended matter larger than a predetermined size from fluid.
7. **Over-Flow Pipe:** It is a conduit through which excess fluid from a pump is by-passed by the action of a relief valve or pressure regulator.
8. **Relief Valve:** It is an automatic device which opens when the pressure of the fluid or gas reaches a predetermined valve.
9. **Pressure Regulator:** It is an automatic device to control the pressure of fluid or gas within a range of settings.
10. **Cut-off Valve:** It is a mechanism between the pump and the nozzle to control the flow of liquid from the sprayer. This is operated by hand.
11. **Nozzle Disc:** It is a component containing the final orifice of a nozzle usually a cone nozzle.

12. Nozzle Boss: It is a lug on spray boom or spray lance to which a nozzle body or cap is screwed.

13. Nozzle Tip: It is a component containing the final orifice of a nozzle usually a fan nozzle.

14. Spray Lance: A hand-held pipe through which the liquid reaches the nozzle mounted at the free end.

Types of Spray:

Sprays may be: 1) High volume spray (more than 400 liters spray/ha), 2) Low volume spray (5 to 400 liters, per hectare), 3) Ultra low volume (ULV) Spray (less than 5 liters spray/ha.)

The selection of technique depends on type of vegetation, kind of pests and approach to the field.

1. **High Volume Spray:** The dilute liquids are applied by hydraulic machines. It consumes more time and labour.
2. **Low Volume Spray:** It uses air stream from a fan as a pesticide carrier with small quantities of liquid. There is saving of material and labour.
3. **Ultra-Lower Volume Spray:** ULV spraying can be defined as plant protection operation in which total volume of liquid applied amount to a few milliliters per acre. It is mainly used in air craft spraying.
4. **Foam Spraying:** In this system a foaming agent (chemical additive) is added to the spraying solution. The spray is passed through a special nozzle. This system is economical.

Ultra Low Volume Sprayer:

The sprayer has a motor powered by 6 or 12 volt battery. To the motor is attached a spinning disc, having grooves or teeth and rotates at a very high revolution per minutes (4000-9000). The spinning disc receives the concentrated chemical from a plastic container having a capacity of 1 liter (approx.). Average droplet size varies between 35 to 100 microns. It is used for application of weedicide and for spraying small trees and crops.

Power Sprayer:

Power sprayers are operated usually with internal combustion engines. The prime mover capacity varies from 1 to 5 HP. The pressure pump is operated by a small power unit ensuring a constant steady pressure. They are operated at pressure from 20 to 55 kg/sq. cm. These machines are usually portable type. Sometimes, power sprayers are operated by the power take-off (PTO) shaft of the tractor besides being pulled by it. Some sprayers are tractor mounted and PTO operated also. A power sprayer essentially consists of: i) Prime mover ii) Tank iii) Agitator iv) Air-chamber v) Pressure gauge vi) Pressure regulator vii) Boom viii) Nozzles.

- i. **Prime Mover:** Prime mover is needed to supply power to the power sprayer. It is usually internal combustion engine. The power generally varies from 1 to 5 H.P.
- ii. **Tank:** Steel tank is widely used to prevent corrosion. Plastic tanks are also getting popular due to freedom from corrosion and ease of moulding into smooth shapes. A covered opening, fitted with a removable strainer is provided for easy filling, inspection and cleaning. A drain plug is there at the bottom of the tank for draining the liquid.
- iii. **Agitator:** Agitators are needed to agitate the liquid of the tank. Propeller or paddle type mechanical agitators are provided for agitating the liquid. Horizontal shaft may be used with flat blades rotating at about 100 to 120 rev/ min. Paddle up speeds in excess of 2.5 m/see may cause foaming.

- iv. **Air Chamber:** An air chamber is provided on the discharge line of the pump to level out the pulsations of the pump there by providing a constant nozzle pressure.
- v. **Pressure Gauge:** The pressure gauge is provided on the discharge line to guide the operator regarding spray pressure. The spray pressure should be under specified limit.
- vi. **Pressure Regulator:** It is meant for adjusting the pressure of the sprayer according to the requirement of the crops in the field.
- vii. **Strainer:** A strainer is included in the suction line between the tank and the pump to remove dust, dirt and other foreign materials.
- viii. **Boom:** Field sprayer to be driven by a tractor has a long boom in a horizontal place on which nozzles are fixed at specified spacing. The boom can be adjusted vertically to suit the height of plants in different fields.
- ix. **Nozzle:** It is used to break the liquid into the desired spray and deliver it to plants. A nozzle consists of: (a) body (b) Screw cap (c) Disc (d) Washer (e) Vortex plate (f) Strainer.

The body of the nozzle and the screw cap hold all the other parts in place. The disc has a number of holes including one hole in the centre and they are usually numbered from one to ten to denote the diameter of the hole. Each number usually denotes about 0.4 mm. The disc needs replacement, when the holes get enlarged due to constant use. The washer under the disc is provided to prevent leakage of the liquid.

Spraying machines can be broadly classified into

1. **Hand Operated Machines:** Suitable for small holdings, they are operated at the pressures ranging from 1 to 7 kg/sq. cm.
2. **Power Operated Machines:** Suitable for treating a large area. They are operated at pressure from 20 to 55 kg/sq. cm.
3. **Air planes:** Suitable for large scale work.

Types of sprayers

1. Bucket Type Sprayer

This equipment consists of a single or double pump which may be placed into any ordinary bucket containing spraying solution. It is very light and easily handled and development sufficient pressure to spray small gardens and low trees.

2. Knapsack Sprayer

The common type of knapsack sprayer is provided with a pump and large air chamber permanently mounted in a 9 to 22.5 liters tank. The apparatus is quite useful for spraying small trees, shrubs and row crops. One man can spray about 0.4 ha. in a day thus spraying about 90 liters of liquid.

3. Compression Sprayer

It consists of an air pump mounted in an air tight chamber which is filled (3/4) the with spraying material. The pressure is developed by pumping air into the tank and the spray is forced out under pressure. The tank capacity is usually 14 liters and frequently pumping is to be done to maintain the pressure.

4. Hand Atomizer

This is the smallest type of hand sprayer used to treat the plants in home garden or nursery and to apply fly spray in the house. In this instrument compressed air is allowed to pass over the end of tube of which the other end dips into the spray material. Blowing air sucks the material through the tube and blows it out of the nozzles as mist.

5. Engine Powered Sprayers

These machines are usually portable types. Since the sprayer pump is driven by an engine there is no variation in output, pressure and performance of the P.T.O. shaft of the tractor besides being pulled by it.

6. Air Plane Sprayers

Either centrifugal pump or a gear pump is used to force the spray liquid through the nozzles. These pumps work at the pressure of about 2.8 to 8.5 kg/cm². The pump sets its driven from a wind driven propeller having four to six blades. The tank capacity may range between 450 to 2550 liters.

Problems

1. Taking pressure as 35 kg/cm², the suction volume Q is 25 lit/min and pump efficiency is 85 per cent. Calculate shaft horse power
2. Find the suction capacity of power sprayer if diameter is 25 mm, speed is 1100 rpm, length of stroke is 22 mm, and number of plunger is 3.

Dusters

Duster is a machine to apply chemical in dust form. Dusters make use of air streams to carry pesticides in finely divided dry form on the plants. A duster essentially consists of a) Hopper b) Agitator c) Feed control d) Fan or blower and e) delivery nozzle.

Types of Duster:

There are several types of dusters in common use, such as:

- 1) Plunger type
- 2) Knapsack type
- 3) Rotary type
- 4) Power operated duster.

1. Plunger Type:

It is a simple duster with a small piston. The piston drives a current of air over the dust in the hopper. The dust is carried away through a delivery spout. Small hand pump dusters of this type are available and are suitable only where the area to be dusted is small like vegetable or flower garden.

2. Knapsack Type Duster:

It is a duster with the powder container on the back of the operator. Knapsack dusters have a hopper through which a current of air is blown to pick up the dust. The air current is produced by lever operated leather blows. Shoulder straps or carrying straps are generally provided in such dusters and they can be easily carried in the fields. These dusters are suited for small areas only.

3. Rotary Duster:

It is a duster with a hand-operated rotor in front of the operator. For spraying tall crops, more force of delivery is required, hence rotary dusters are preferred. Dust is fed from a hopper into a current of air produced by a rotary fan and is blown out through a delivery pipe. Most of the models have stirring device, actuated by the fan crank to ensure a steady flow of dust. The rate of delivery can be regulated by a valve below the hopper. The delivery force is controlled by controlling the speed of the fan.

4. Power Operated Duster:

Power operated duster mainly consists of a power driven fan, a hopper and a delivery spout. The fan creates strong airflow, which causes the dust to blow off from the hopper to a considerable distance either vertically or horizontally. The direction of the dust is regulated by a movable delivery spout suitably fitted with the unit. These types of dusters are used for large areas.

Care and Maintenance of Dusters:

1. Duster should be thoroughly cleaned before and after use with suitable brush.
2. The hopper should be fitted with dust about half of its capacity.
3. The lid of the hopper should be closed during the operation.
4. In rotary dusters, handle should be cranked at 30 to 35 revolutions per minute for efficient performance.
5. Before storing the duster after use, the dust from the fan box, suction pipe and hopper should be thoroughly blown out and the agitation shaft should be profusely oiled while cranking.
6. Pieces of paper, sacking and other foreign materials should be prevented from getting into the hopper.
7. The agitator parts and dust feed should be occasionally checked for blockage by foreign matters.

Essential Spare Parts to Be Kept in Stock:

- i) Agitator, ii) Feed control lever, iii) Feeding brush, iv) Shaft for crank, v) Crank handle, vi) Hose couplings and clips, vii) Breast plate, viii) Nozzle, ix) Nuts and screws.

General Precautions for the Safe Use of Insecticides:

1. The name on container should be read carefully and manufacturer's instruction should be followed.
2. The pesticides should be kept always in container with proper name.
3. The pesticides should be stored in a safe and locked place so that children may not touch them.
4. The pesticides should never be placed near foodstuff or medicines.
5. Empty containers of dangerous pesticides should not be used for any alternative purpose.
6. Necessary protective clothing should be used while handling pesticides. The pesticide bags should not be torn but it should be cut with a knife.

Seed Dresser: It is a machine to apply coating of protective chemicals to seeds.

Fumigator: It is a machine to generate and distribute gases or smoke.

Flame Gun: It is an apparatus to kill weeds by a flame.

Power Sprayer cum Duster: It is a power operated sprayer, which can be converted as duster when desired.

Exercise No. 15 : Study of Harvesting and Threshing machinery

Harvesting: It is the operation of cutting, picking, plucking, digging or a combination of these operations for removing the crop from under the ground or above the ground or removing the useful parts or fruits from plants.

Harvesting plants The operation of cutting a plant is achieved by four different actions. (1) slicing action with a sharp smooth edge, (2) tearing action with a rough, serrated edge, (3) high velocity single element impact with sharp or dull edge, and (4) a two element scissor type action.

Sickle:

It is a simple harvesting tool. It is used for harvesting crops and cutting other vegetations . It is essentially consists of a metallic blade and a wooden handle. Blade is the main metallic part of the sickle. It is desirable to make the blade of carbon steel. It is made in a curved shape. The tooth of serrated sickle is made sharp for efficient working in the field. The handle of the sickle is made of well seasoned wood.

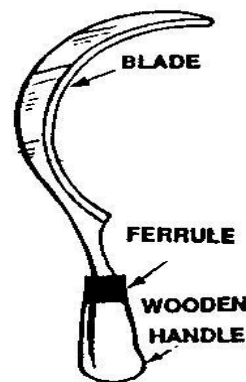

Sickle

The forged end of the blade for fixing the handle is called tang. The plain or serrated edge in the inner side of the blade is called cutting edge. Protective metallic bush fitted at the junction of the blade and the handle to keep the tang tight in the handle is called ferrule. Harvesting by sickle is very slow and labour consuming device.

Reaper :

Animal drawn reaper : Reaper is a machine to cut grain crops. It is pulled by a pair of animals. It can harvest nearly 5 to 8 cm above the ground. The machine consists of frame, cutter bar, knife, wheels, bearings and other attachments. Frame is usually made of mild steel sections. The cutter bar knife is made of high carbon steel. The shoes are usually made of malleable casting. Usually two persons are required to operate the machine. One man guide the animals and another man is engaged in dropping the cut crops from platform to the ground.

Threshing: It is the process of detaching grains from the earheads or from the plants.

Power thresher:

It is a machine operated by a prime mover such as electric motor, engine, tractor or power tiller used for threshing.

A power thresher performs several functions such as:

- i) To feed harvest to the threshing cylinder
- ii) To thresh the grain out of the head
- iii) to separate the grain from the straw
- iv) to clean the grain
- v) To put the grain in the bag
- vi) To make the chaff suitable for animal feeding

Types of Power threshers:

- i) Hammer mill type: It is a thresher with threshing unit consists of hammers or beaters with closed cylinder casing and concave. It is equipped with a set of oscillating sieves an aspiratory blower for separation and cleaning of grains.
- ii) Rasp-bar-cylinder type : In this thresher the threshing unit consists of bars with serrations having an open concave.

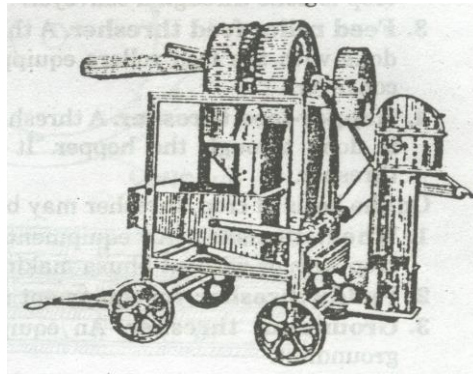
**Power thresher**

- iii) Spike-tooth type : In this thresher the threshing unit consists of drum having rows of spikes with closed cylinder casing and concave. It is equipped with a set of oscillating sieves an aspiratory blower for separation and cleaning of grains.
- iv) Syndicator type : In this thresher the threshing unit consists of a corrugated fly wheel with serrated chopping knives and a closed cylinder casing and concave. This is also called as chaff cutter type thresher.
- v) Drummy type : It is a hammer mill type thresher without separation and cleaning unit.

On the basis of feeding system threshers are four types as :

- i) Chute-feed thresher.
- ii) Conveyor feed thresher
- iii) Feed roller feed thresher
- iv) Hopper feed thresher

On the basis of crop threshers are Six types as :

- i) Wheat thresher
- ii) Paddy thresher
- iii) Groundnut thresher
- iv) Millet thresher
- v) Soyabean thresher
- vi) Multicrop thresher

Components of Power Thresher :

- i) Concave : It is a concave shaped metal grating partly surrounding the cylinder against which the cylinder rubs the grain from the plant or earheads and through which the grains fall on the sieve.
- ii) Cylinder or Drum : It is a balanced rotating assembly comprising rasp,beater bar or spikes on its periphery and their support for threshing the crop. There are five cylinders commonly used as : i) peg tooth or spike tooth cylinder ii) Rasp- bar cylinder iii) Angle bar cylinder iv) Loop type cylinder v) Hammer mill type cylinder
- iii) Cleaning Unit : The function of cleaning unit is to separate and clean the threshed grain. The cleaning unit mainly consists of two or more oscillating sieves, a fan and an air sucking duct known as aspirator. Usually two ducts are there, one primary and other secondary duct. The function of the primary duct is to remove major portion of straw, dust and other foreign matter. The secondary duct is used for final cleaning of the grains.

Threshing efficiency depends upon : i) Peripheral speed of the cylinder ii) Cylinder- concave clearance iii) Type of crop iv) Moisture content of crop v) Weather condition vi) Feed rate.

Combine harvester :

Combine harvester is a machine designed for harvesting, threshing, cleaning and collecting the grain while it moves over the land. All the five operations are carried out in single operation of the harvester. The machine is versatile and with minor adjustments can handle a variety of crops. The size of the combine is indicated by the width of cut, it covers in the field.

Combine harvester in its primitive form was introduced in Germany and U.S.A. in late 19th century and became popular in next decades. In India, though a few tractor drawn combine harvesters manufactured by Minneapolis Moline U.S.A, and self-propelled Russian combine harvesters were available with some Govt. farms and landlords. However, between 1970-73 introduction of E512 GDR combine in Punjab, Haryana and M.P. was made in a big way. This was another revolution in the farm mechanization sector. Gradually indigenous production started with the manufacture of a Swaraj 8100 combine harvester in organized sector by M/s Punjab Tractors Ltd., which followed manufacturing of the machine in small sector in a small way. Surprisingly in 30 years of its production on commercial scale in India there are 60 more manufacturers with a production capacity of 5 to 150 combines per year. On an average about 800 combines are added every year on Indian farms. All these manufacturing units are located in the state of Punjab.

Functions of combine harvester

1. cutting the standing crops
2. Feeding the cut crops to threshing unit
3. Threshing the crops
4. Cleaning the grains from straw
5. Collecting the grains in a container

Problem No.1 Calculate the total time required to harvest 2.5 hectare of grass by means of a 2m mover operating at a speed of 4kmph. Take field efficiency of mover as 80%.

Solution :

$$\begin{aligned} \text{Actual Area covered, Ha, } A &= [(W \times S) / 1000] \times (E / 100) \times \text{Time} \\ 2.5 &= [(200 \times 4) \times 80 / (1000 \times 100)] \times \text{Time} \\ \text{Time} &= (2.5) / [(200 \times 4) \times 80 / (1000 \times 100)] \\ \text{Time} &= 3.9 \text{ Hours} \end{aligned}$$

Problem No. 2 : What hp will be required to pull 1.2 m mover working at a speed of 4.8 kmph. If there is a load of 50 kg per metre length of the mover and mechanical efficiency is 80%.

Solution :

$$\begin{aligned} \text{Total load} &= 1.2 \times 50 = 60\text{kg} \\ \text{Total Power} &= \text{Draft (kg)} \times \text{Speed (kmph)} / 270 \\ &= (60 \times 4.8 / 270) = 1.066 \text{ hp} \\ \text{hp required to pull the mover} &= (1.066 \times 100 / 80) \\ &= 1.33 \text{ hp} \end{aligned}$$

.....

Dept. of Agril. Engg. V.N.M.K.V., Parbhani

Exercise No.16 : Study of Power tiller- important parts and Attachments

Power Tiller:

It is a prime mover in which the direction of travel and its control for field operation is performed by the operator walking behind it. It is also known as Hand Tractor or walking type tractor. The operator walks behind the power tiller, holding the two handles of power tiller in his own hands. Power tiller may be called a single axle walking type tractor, though a riding seat is provided in certain designs.

Components of power tiller

A power tiller consists of the following main parts

1. Engine.	2. Clutch	3. Transmission gears
4. Brakes	5. Rotary unit	

All the power tillers are fitted with an I.C. engine. At present most of the power tillers are fitted with diesel engine. Only Iseki make have used kerosene engine. Other makers like Kubota, Mitsubishi, Krishi Yanmar and Satoh have used diesel engine in India.

Operation:

The main clutch is a lever on the handle. The lever can be shifted to on or off position while operating in the field. When the lever is shifted to on position, the power from the engine is transmitted through the main clutch to the various parts of the power tiller. When the lever is shifted to off position, the power from the engine is cut-off from the rest of the transmission.

Power transmission in power tiller

For operation of power tiller, the power is obtained from the I.C. engine, fitted on the power tiller. The engine power goes to the main clutch with the help of belt or chain. From main clutch, the power is divided in two routes, one goes to transmission gears, steering clutch and then to the wheel. The other component goes to the tilling clutch and then to the trilling attachment.

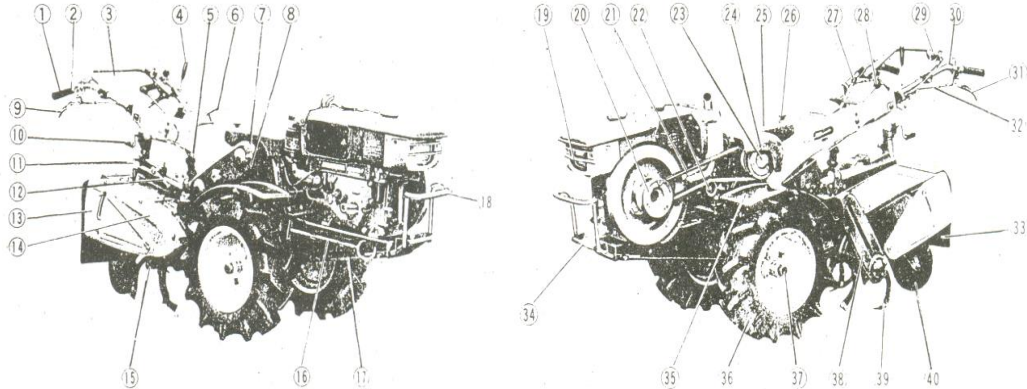

No.	Name of parts	No.	Name of parts
1	Handle grip	31	V-belt
2	Throttle lever	22	Tension pulley
3	Auxiliary handle	23	Main clutch pulley
4	Main gearshift lever	24	Belt cover
5	Hanger	25	Handle cover
6	Front stand operating lever	26	Handle cover grip
7	Auxiliary chain case set screw	27	Tine speed change lever
8	Auxiliary chain case	28	Main gear shift lever
9	Steering clutch lever (right)	29	Hand light

10	Rear wheel height adjusting lever	30	Lamp switch
11	Rear wheel pipe attaching handle	31	Steering clutch lever (left)
12	Ridger set screw	32	Steering clutch wire
13	Mud-guard (right)	33	Rubber guard
14	Side cover(right)	34	Protector
15	Tilling tines	35	Fender left
16	"Magic Bar"	36	Rubber tire
17	Front frame	37	Hexagon wheel tube
18	Protector	38	Side frame
19	Front lights	39	Tilling tines
20	Engine pulley	40	Rear wheel

The flow chart for transmission of power is given below.

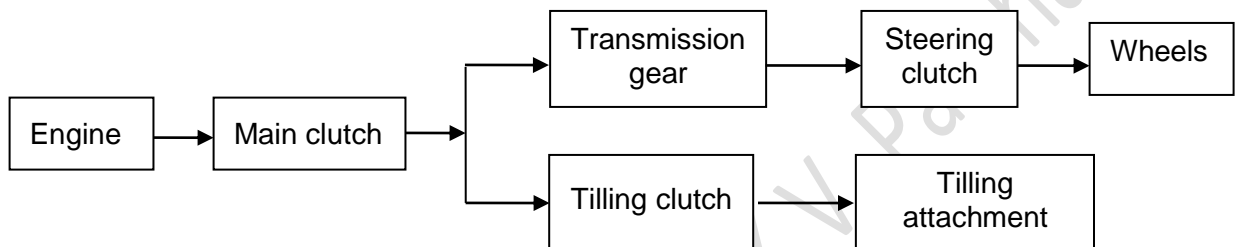

V-belt is usually used to transmit power from the engine to the main clutch, because V-belt has very high efficiency and it works as a shock absorber also.

Main clutch Power goes from the engine to the main clutch. Clutch may be

a. Friction clutch or b. V-belt tension clutch

Friction clutch is generally used for bigger power tiller. Usually it is a dry type multiple disc clutch. V-belt tension clutch is used for small power tiller. The main functions of clutch in a power tiller are:

- to transmit engine power to transmission gears and
- to make power transmission gradual and smooth.

Transmission gears. Transmission box consists of gears, shafts and bearing. The speed change device may be: a. gear type or b. belt type

Brakes: All power tillers have some braking arrangement for stopping the movement. Most of the power tillers use inner side expansion, type brake

Wheels: Usually 2 to 4 ply pneumatic tyres are used in power tillers. The pressure of the tyre ranges from 1.1 to 1.4 kg/cm².

Rotary unit: Power tiller has a rotary unit for field operation.

Rotary unit is of two types:

- Centre drive type and
- Side drive type

- Centre drive type has got transmission at the centre and the side drive type has the transmission at one side.

Centre drive type has the following characteristics:

- Tilling width can be widened.

- b. Rotary unit is light in weight'
 - c. Fixing of attachment is easy
 - d. The tine shaft can be detached easily
 - e.]Mounting and dismounting of rotary unit is very easy
 - f. It may leave some portion of the field untilled
 - g. It has one point support on the ground.
2. In side drive type:
- a) Deeper tilling is possible.
 - b) The arrangement is useful for hard soil
 - c) It has two point support on the ground

Rotary tines: Rotary tines are used in rotary unit for soil cutting and pulverization purpose.

Rotary tines are of three types:

1. Straight tines
2. curved tines and
3. Siding tines

In case of straight tines

- a. Power consumption is less
- b. Fine pulverization of soil is possible.
- c. Poor soil turning
- d. Grass entangles in the tines very easily.
- e. It is suitable for hard soil

In case of curved tines:

- a. Good soil turning is possible
- b. It is suitable for avoiding grasses
- c. Pulverization of soil is coarse and
- d. Power consumption is high.

Siding tines have the characteristics of sliding on their position according to the requirements

- a. the tines can be arranged in 3 ways:
- b. Inner heap (to break the ridges)
- c. Outer heap (to make the ridges) and
- d. Even arrangement.

Steering clutch lever: Steering clutch is provide on the grip of the right and left handles. When the left side is griped, power is cut-off on left side of the wheel and the power tiller turns to the left. Similarly when the right side is gripped, the power tiller turns to the right.

Rotary tilling

A Plane Tilling:

There are various ways of tilling by the rotary tiller, but the method most commonly used at present is the 'every other row tilling' method because it is very efficient and is very simple.

1. Every other row tilling method:

Take the power tiller and put it into the paddy field which is to be tilled, and first till along the levee on the long side. Next, leaving a space which is little narrower than the tilling width (this depends upon the skill of the operator bur a width of about 3 to 6 cm) till the whole paddy field. In other words, the every other row tilling method is tilling with a

space between the tilling. After every other row tilling method has been completed till the place which has not been tilled. In this case, the front wheels will pass over a place which has previously been tilled so it would sink a little, which in other words means that the tilling would be a little deeper than the previously tilled parts. Therefore, by the use of the rear wheel height adjusting lever, raise the rotary part a little so that the foundation of the tilling would be the same for both tilling.

At the end, the headlands which have been left untilled should be tilled. When the headland is finished, the tilling job is finished.

2. Close by tilling method:

In case by tilling method whole field is tilled in an orderly fashion, one row after another. This method requires a comparatively high skill so it is not commonly adopted. One of the wheels passes over a tilled plot.

A. Puddling : If a puddler and filed leveler is attached to the rear of the rotary tiller, it is possible to do efficient puddling work to a width of about 1.5 metre to 2 metre

B. Ridging: The ridger should be attached and adjusted in the power tiller.
The following are some of the methods in doing riding work.

1. **Ridge with core:** Attach a ridger to the rotary tiller and make the ridges by doing ridging work together with the rotary work.

Advantages:

- i. Drainage is very good in wet paddy fields
- ii. Very efficient

2. **Ridge by every other row method:** First make the rotary tilling tines face inwards and attach the rear two wheels, then till in the every other row method. When this is finished, turn the tilling tines outside and attach the ridger and make ridges on the untilled part.

Advantages:

- i. the soil will be uniformly pulverized
- ii. Machine proceeds very straight
- iii. There is restriction on the width of the ridge.

3. **Ridge after plane tilling:** First till the whole plot of land by the ordinary rotary tilling method. In doing this take into consideration the progress of the ridge work to be done later and be very careful to proceed straight, next, turn the tilling tines outwards, set the ridger and do the ridging work.

.....

Course :	ENGG - 232		Credit:	2(1+1)	Semester-III
Course title:	Farm Machinery and Power				

Syllabus

Theory

Status of Farm Power in India, Sources of Farm Power , Scope of Mechanization, I.C. engines, working principles of I C engines, comparison of two stroke and four stroke cycle engines , Study of different components of I.C. engine, I.C. engine terminology and solved problems, Familiarization with different systems of I.C. engines: Air cleaning, cooling, lubrication ,fuel supply and hydraulic control system of a tractor, Familiarization with Power transmission system : clutch, gear box, differential and final drive of a tractor, Tractor types, Cost analysis of tractor power and attached implement, Familiarization with Primary and Secondary Tillage implement, Implement for hill agriculture, implement for intercultural operations, Familiarization with sowing and planting equipment, calibration of a seed drill and solved examples, Familiarization with Plant Protection equipment, Familiarization with harvesting and threshing equipment.

Practical

Study of different components of I.C. engine. To study air cleaning and cooling system of engine, Familiarization with clutch, transmission, differential and final drive of a tractor, Familiarization with lubrication and fuel supply system of engine, Familiarization with operation of power tiller, Familiarization with different types of primary and secondary tillage implements: mould plough, disc plough and disc harrow . Familiarization with seed-cum-fertilizer drills their seed metering mechanism and calibration, planters and transplanter Familiarization with different types of sprayers and dusters Familiarization with different inter-cultivation equipment, Familiarization with harvesting and threshing machinery.

Teaching Schedule

a) Theory

Lecture	Topic	Weightage (%)
1	Sources of farm power in ..Human, Animal, Mechanical, electrical, solar, Wind Power, Scope of Mechanization.	6
2-3	Principle of operation of I.C. engine- I.C. engine working principles Two and Four stroke engine, Engine terminology and examples	13
4-5	I.C. Engine systems -Fuel supply system, cooling system, Air cleaner, lubrication of tractor.	12
6-7	Tractor -Tractor types and their selection, fixed and operating cost of tractor power and attached implements with examples	13
8	Tillage - Tillage, objectives of tillage, classification & types of tillage, Tillage implements	7
9	Primary tillage implements - M. B. plough and Disc plough, Rotavator, with examples	6

Lecture	Topic	Weightage (%)
10	Secondary tillage implements - Harrows, cultivators & examples	6
11-12	Implements for inter-culturing operations - Hand tools, Improved hoes, Wheel hoe, Multipurpose hoe, Tractor drawn intercultural equipments	12
13	Seed drills - Sowing methods, seed drill, components of seed drill, seed metering mechanism (Fluted roller and plate type only) , types of furrow openers, calibration of seed drill, examples	7
14	Study of planter -Planter, Functions, seed metering devices, type of planters, solved examples	6
15	Plant protection equipments - Classification, types of spraying and types of dusting machines.	6
16	Harvesting and threshing equipments -Definition of harvesting and threshing, harvesting /threshing methods implements , mower and combine harvester-thresher, solved examples	6
	Total	100

b) Practical

Experiment	Topic
1.	Study of components of internal combustion (I. C.) engine
2.	Study of two stroke cycle engine
3.	Study of four stroke cycle engine
4.	Study of Fuel supply systems for S. I. engines
5.	Study of Fuel supply systems for C. I. engines
6.	Study of Air Cleaning and Cooling systems of an engine
7.	Study of Lubrication system
8.	Study of clutch, Gear box and differential unit of the tractor
9.	Study of primary tillage implements: mould board plough and disc plough
10.	Study of secondary tillage implements- harrows and cultivators.
11.	Study of inter-culturing tools and implements- manual and animal drawn.
12 & 13	Study of seed-cum-fertilizer drill and calibration of seed drill.
14.	Study of sprayers and dusters
15.	Study of harvesting and threshing machinery
16.	Study of power tiller- important parts and attachments

Suggested Readings

- 1) Principles of Agricultural Engineering Vol. 1. Reprint Edition: 2012. by T. P. Ojha, A. M. Michael, Jain Brothers, New Delhi
- 2) Elements of Agricultural Engineering by JagadishwarSahay. Forth Edition, 2010 Standard Distributor and Publishers, New Delhi
- 3) Agricultural Engineering by O P Singhal (2011) Aman Publishing House, Meerut
- 4) Elements of Farm Mechaneries by A C Srivastava, Oxford and IBH Publishing Co Pvt Ltd, New Delhi
- 5) Farm Tractor -Repair and Maintenance by S.C. Jain and C.R. Rai.
- 6) Principles of Farm Machineies by R A Kepner, R Bainer, E C Barger (2000) CBS Publishers and Distributors, Delhi
- 7) Farm Engines and Tractors by H E Gulvin (2001) McGraw Hill, New York
- 8) Servicing and Maintenance of Farm Tractors (2005) E J Johnson and A H Hollenburg, McGraw Hill, New York
- 9) Tractor Implement System by Alcock and Ralph (1986) Athe AVI Publishing Co. Inc Springer, New York



**VASANTRAO NAIK
MARATHWADA KRISHI VIDYAPEETH,
PARBHANI : 431 402**

College of Agriculture,

CERTIFICATE

This is to certify that Mr. / Miss
Reg. No..... a student of III Semester **B.Sc. (Agri.)**
has completed all the exercises successfully of the Course :
Farm Machinery and Power Course No. : **ENGG-232**
during Monsoon Semester 201 - 201 .

Place :

Date :

COURSE TEACHER

PRACTICAL MANUAL

Course Title : **Farm Machinery & Power**
Course No. : **Engg - 232 (1+1=2)**
Semester : III
Course : B. Sc. (Hons.) Agriculture

INDEX

Ex. No	Name of the Exercise	Page No	Date	Signature
1.	Study of components of internal combustion (I. C.) engine	01		
2.	Study of two stroke cycle engine	04		
3.	Study of four stroke cycle engine	06		
4.	Study of Fuel supply systems for S. I. engines	07		
5.	Study of Fuel supply systems for C. I. engines	08		
6.	Study of Air Cleaning and Cooling systems of an engine	09		
7.	Study of Lubrication system	12		
8.	Study of clutch, Gear box and differential unit of the tractor	14		
9.	Study of primary tillage implements: mould board plough and disc plough	18		
10.	Study of secondary tillage implements- harrows and cultivators.	22		
11.	Study of inter-culturing tools and implements- manual and animal drawn.	26		
12.	Study of seed-cum-fertilizer drill	28		
13.	Study of Calibration of seed drill.	29		
14.	Study of sprayers and dusters	31		
15.	Study of harvesting and threshing machinery	36		
16.	Study of power tiller- important parts and attachments	40		
	Syllabus	44		

Dept. of Agril. Engg. V.N.M.K.V., Parbhani